

SECTION VIEW

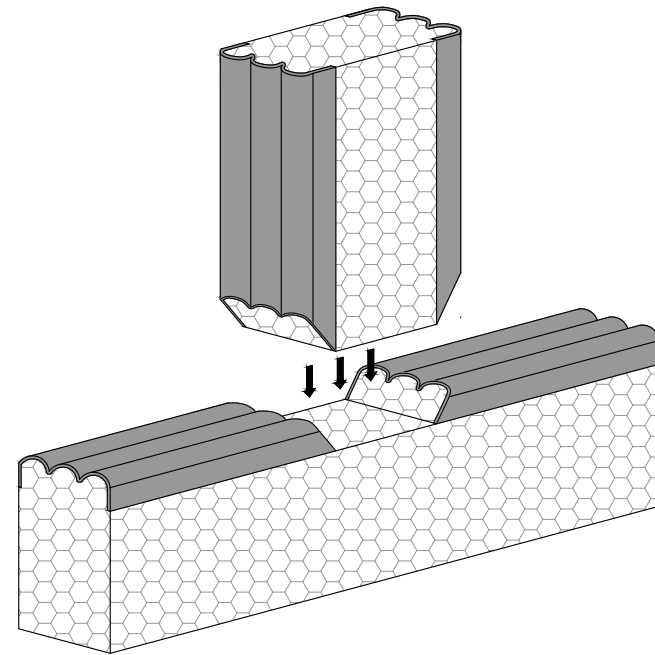

ISOMETRIC VIEW

NOTE: REFER TO TREMCO'S PUBLISHED APPLICATION INSTRUCTIONS FOR ACCEPTABLE JOINT SIDE WALL SUBSTRATE CONDITIONS PRIOR TO INSTALLATION

WILLSEAL JOINT PREPARATION :

1. CUT THE WILLSEAL FR-H AT A 45° ANGLE THROUGH THE SILICONE FOLLOWED BY A HORIZONTAL CUT THROUGH THE FOAM SECTION. ENSURE THE LENGTH OF THE CUT ACCOMMODATES THE ADJOINING WILLSEAL FR-V.
2. CUT THE WILLSEAL FR-V AT A 45° ANGLE THROUGH THE SILICONE. INSTALL THE WILLSEAL FR-V WITH A 1/2" TO 1" OVERLAP INTO WILLSEAL FR-H TO MAINTAIN PROPER COMPRESSION.
3. APPLY SUPPLIED FIRESTOPPING SPLICE ADHESIVE TO THE ADJOINING FACES OF WILLSEAL FR-H AND WILLSEAL FR-V.
4. PRESS COMPONENTS TOGETHER AND INSTALL INTO JOINT.
5. TOUCH UP SILICONE BELLOWS USING SUPPLIED SILICONE.
6. RESUME STANDARD INSTALLATION INSTRUCTIONS.

*This detail is for general informational purposes, only. The project design professional determines, in its sole discretion, whether this detail or a functionally equivalent detail is best suited for the project with respect to any architecture, engineering, and design requirements, including any local building code requirements. If this document is not reviewed and the product is not approved for use by a licensed design professional, the customer agrees that the detail may contain substantive flaws requiring correction, and hereby releases Schul International Co., LLC d/b/a Willseal from any and all liability related to the design and installation of the product. This detail is subject to change without notice. Contact Willseal to ensure you have the most recent version.*

Willseal FR-H



Willseal Technical Support: 800-274-2813

Detail: Willseal FR-V to Willseal FR-H at T-Joint

Drawn by: HDE

Checked by: AM/NF/JC

Scale: NTS

Revision #: 0

Revised by: NA

Date: 1/15/2025

File Name:

WFRH-FW-T-01



Construction Products Group

www.tremcocpg.com