

NOTES

1. THE CURBS, TOP WOOD NAILER AND SEAL STRIP ARE TO BE SUPPLIED BY THE CURB MANUFACTURER.
2. WHEN POSSIBLE, THE MECHANICAL UNITS SHOULD NOT BE SET UNTIL THE ROOF MEMBRANE AND FLASHING HAVE BEEN INSTALLED.
3. WHERE THE SKYLIGHT, SCUTTLE OR SMOKE VENT FRAME OVERLAPS THE BASE FLASHING AT LEAST 3 INCHES, THE REMOVABLE SHEET-METAL COUNTERFLASHING IS NOT REQUIRED.
4. PRIMING OF THE SUBSTRATE MAY BE REQUIRED. FOLLOW SPECIFICATIONS AND MANUFACTURER'S RECOMMENDATIONS.

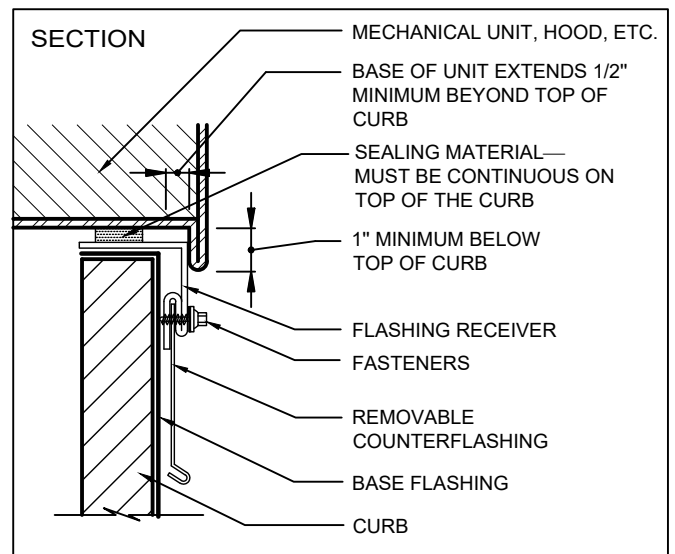

SHEET TITLE:
**BASE FLASHING AT WOOD
 CURB FULLY REINFORCED
 OVER CONCRETE**

SCALE:
 NTS
 DRAWING No.:
DWG NO. LA-CFR-13